

JA SOLAR

DEEP BLUE 3.0

DeepBlue 3.0

TECHNICAL WHITE PAPER

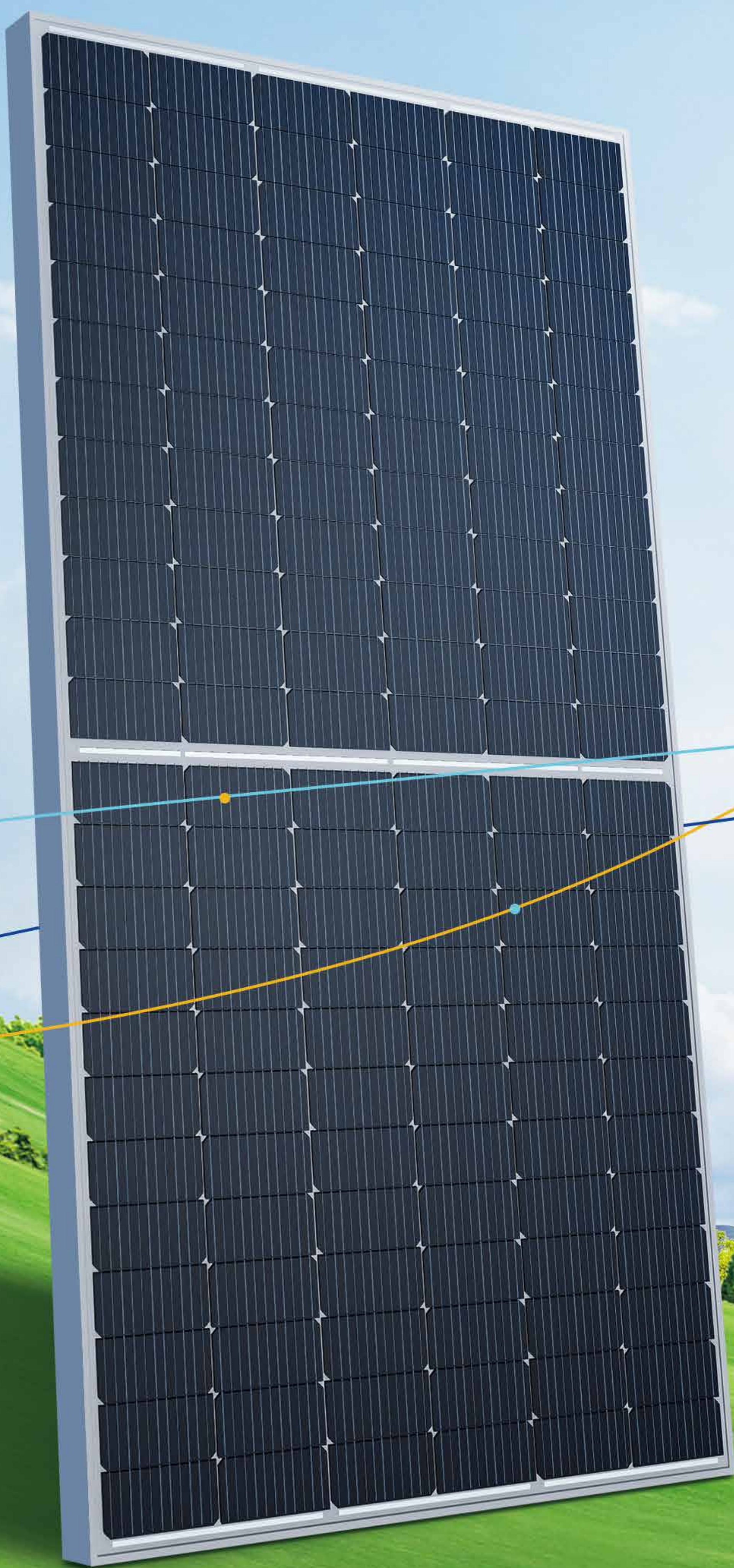

01 PART

EMERGENCE BACKGROUND

The development of the PV industry is a continuous pursuit of the lowest levelized cost of electricity (LCOE), especially at the critical moment of global energy transition, reducing cost and improving efficiency in relation to PV modules has become an important way to reduce LCOE, which is usually achieved in two ways: continuous improvement in the cells' conversion efficiency and module power output and constant decrease in the cost per watt of PV modules.

In recent years, PV power generation technology seems to be updated at a quicker pace, as evidenced by the faster-than-conventional speed in updating product technology. Especially since 2019, as driven by large-size silicon wafer technology, there have appeared various types of ultra-high-power modules, directly pushing up the most leading module power from 410W in 2019 to 445W in the first half of 2020 and further to 500W+ or even higher in the second half of 2020.

JA Solar has always taken technological innovation as its development foundation, especially since the start of 2020, JA Solar has further increased its product R&D investment. By applying multiple technologies including M10 wafer (182mm size) technology, PERCIUM+ technology, multi-busbar (MBB) and half-cell technology, etc., JA Solar has launched its powerful product -- Deep-Blue 3.0, a high-efficiency and high-power PV module which brings customers a lower LCOE solution with the power of modules available for mass production up to 590W at the moment.

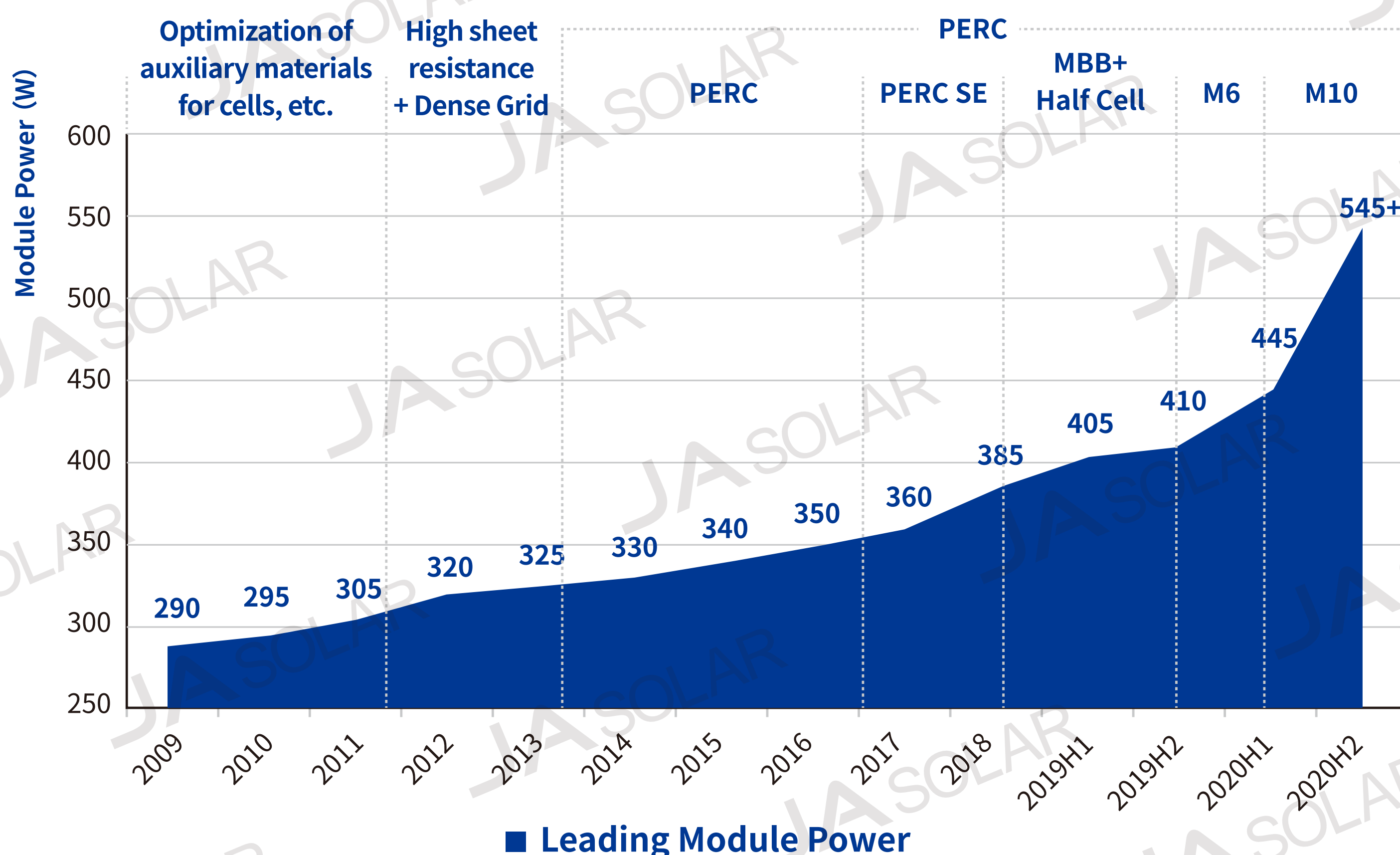

■ Leading Module Power
 Module power development trend and main efficiency improvement methods

02 PART

DESIGN PRINCIPLE

DeepBlue 3.0 aims to reduce LCOE and increase customer value by adopting large-size silicon wafers with 182mm size applying new-generation PERCIUM+ high-efficiency cell technology, and optimizing module size and layout.

The size of PV silicon wafers first originated from semiconductor silicon wafers, therefore, during a long time, the PV industry had been using the 6-inch and 8-inch semiconductor silicon wafers, i.e. 125mm and 156mm PV wafers. At the end of 2013, several major PV companies took the lead to unify standard size of silicon wafers as 156.75mm. Since 2015, 156mm silicon wafers had gradually been replaced by 156.75mm silicon wafers. In 2018, 158.75mm silicon wafers gradually occupied the market, and in 2019, the introduction of 166mm and 210mm silicon wafers initiated the competition in the size of large-size silicon wafers. By this time, the PV industry had no longer followed the semiconductor industry standards but the lowest LCOE in PV system in choosing the size of silicon wafers.

Following a reverse design thinking for the industry chain, JA Solar has determined the current optimal large-size module solutions centering on customer value after considering LCOE and actual condition of various links including production, transportation, installation, system matching and system performance, etc., and the DeepBlue 3.0 series based on 182mm x 182mm wafers came into being.

1) Supply of raw materials

The supply of corresponding auxiliary materials is crucial to large-size PV modules. As the size of PV backsheet and EVA of 182mm products can be flexibly adjusted, there is no bottleneck in size; for PV embossing glass, the fully mature glass supply chain for 182mm products indicates there is no problem with technology and production capacity.

2) Maturity of equipment

The industry chain of production equipment for 182mm products is highly mature. In terms of crystal pulling, most furnaces can be used for pulling high-quality and low-cost large size monocrystalline silicon rods after initial upgrade; regarding cell and module, little equipment upgrading is needed and there is abundant successful experience for reference.

3) Technique popularization rate

- ◆ In the crystal pulling link, the crystallization rate of 182mm products is basically the same as that of 158mm products, and the per unit yield is also the same at present. There is still space for growth in per unit yield in the future.

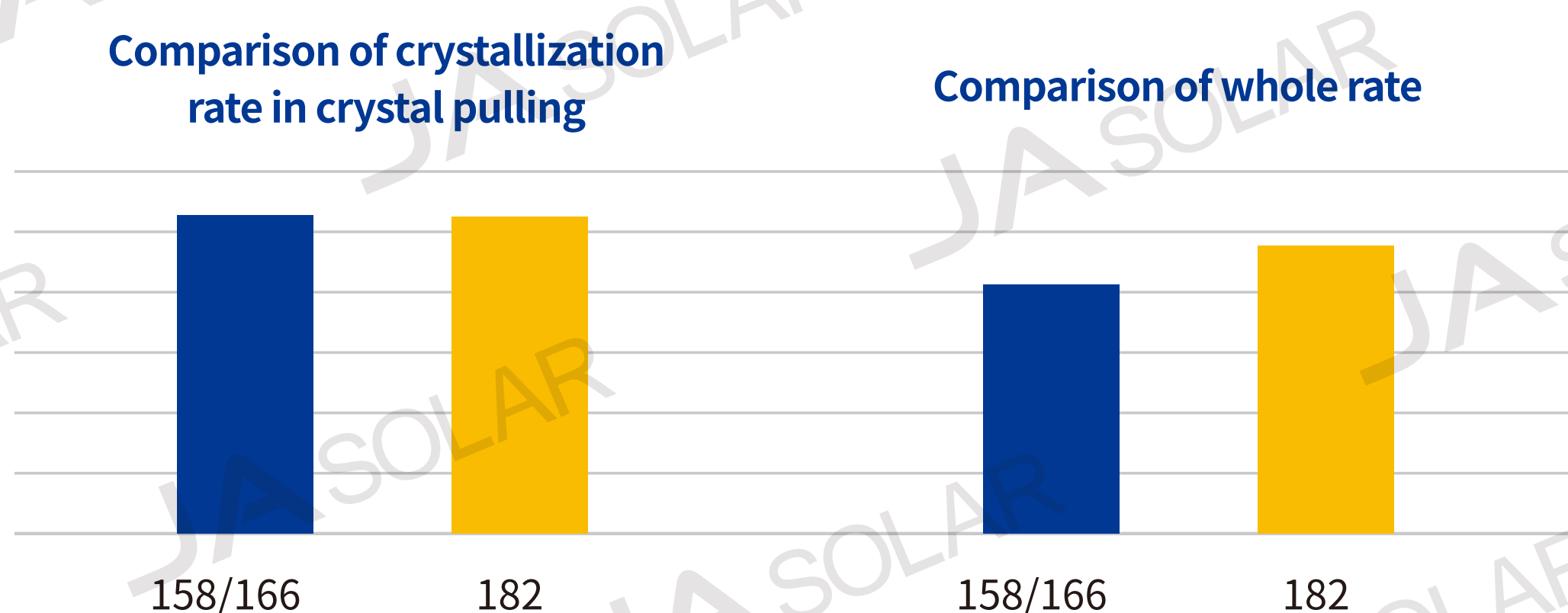

Comparison of crystal pulling for 182mm products and 158/166mm products

- ◆ In the slicing link, the yield of 182mm products is basically the same as that of 166mm products.
- ◆ In cell production procedure, 182mm series products have outstanding performance in diffusion and PECVD uniformity, and the yield rate and cell conversion efficiency are the same as those of 166mm products.
- ◆ In the module production procedure, the laser half-cutting technology is mature and the existing module equipment is well matched with the 182 series products.

4) Minimum transportation costs

In practice, expensive international transportation limits the size of PV modules. PV modules are generally packed in containers for international sea transportation. Containers are internationally standardized transportation carriers with fixed size. Therefore, the transportation costs can be reduced by making the best use of the container capacity. Under this premise, upon calculation, compared to the existing 166mm and 210mm series modules in the market, the large-size modules based on 182mm silicon wafers can maximize the use of container capacity, saving transportation costs.

5) Reasonable handling and installation

The size and weight of the 182mm modules are within a reasonable range for manual handling. Normally, two persons are needed to carry and install the PV modules, and the up-weight limit shall be below 40kg for larger-module, which is within the weight range for manual handling. Moreover, the module size is also suitable for carrying by workers. An adult's arm span is about 1.7 meters and the width of 182mm modules is around 1130mm. So, the width is within the

flexible operating range of the arms.

6) System compatibility

Primary consideration will be given to the compatibility with the mounting system and inverter. Regards to Structure, 182mm modules are compatible with the mainstream installations such as fixed structure and trackers; as for inverters, 182mm modules are fully compatible with all mainstream central inverters. Regarding string inverters, mainstream inverter manufacturers have launched or plan to launch solutions to match large currents.

7) Manufacturing cost and BOS cost

The integrated manufacturing cost of 182 series products is significantly reduced based on compatibility with all industry links. The upgrade of silicon wafer size plays a positive role in reducing the cost per watt. However, it does not mean the larger the wafer size, the lower the integration cost, as the flux value resulting from oversized wafers may be offset by the wafer and module side. Given similar module efficiency, an appropriate increase in module size can effectively reduce BOS cost, but further increase in module size causes increasingly insignificant decrease in BOS cost, and the risk of mechanical load, difficulty in transportation and installation, bearing capacity of structures and other limitations brought by the increase in size greatly reduce the actual utility of modules. Therefore, the biggest is not necessarily the best for module size. Instead, a comprehensive evaluation on the whole industry chain and the whole PV system should be conducted to obtain a reasonable size, the optimal manufacturing cost, variable BOS cost and LCOE.

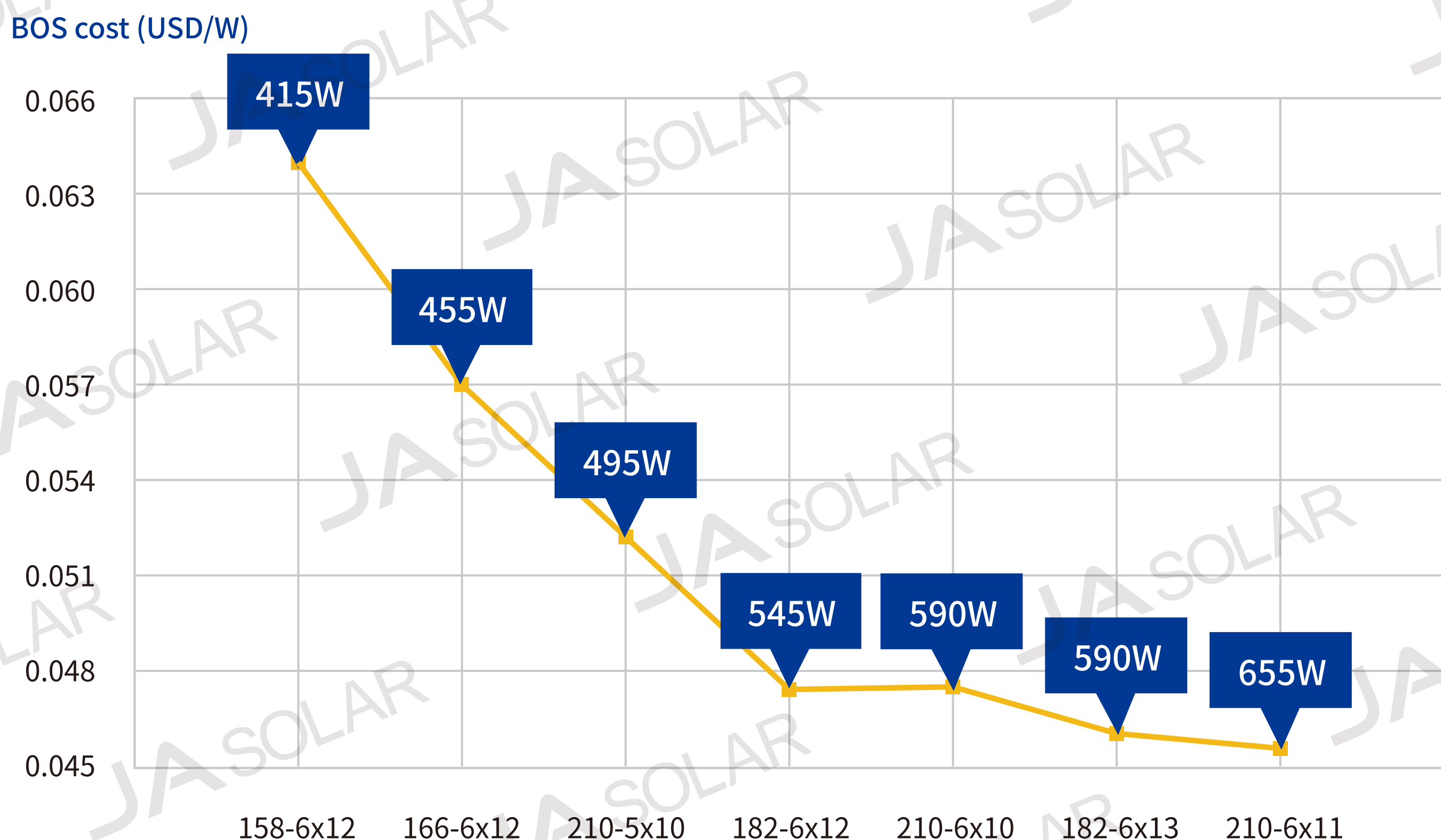

Relationship among module power, size and BOS cost (variable BOS cost (USD/W))

To sum up, compared with the existing products, DeepBlue 3.0 products feature smaller span in process, higher maturity of existing equipment and process, less difficulty and low cost in upgrading production lines, small limitation in supply materials, low manufacturing cost per watt under integration, and low BOS cost, therefore, we finally decide to use 182mm silicon wafers and design modules of 66/72/78-cell.

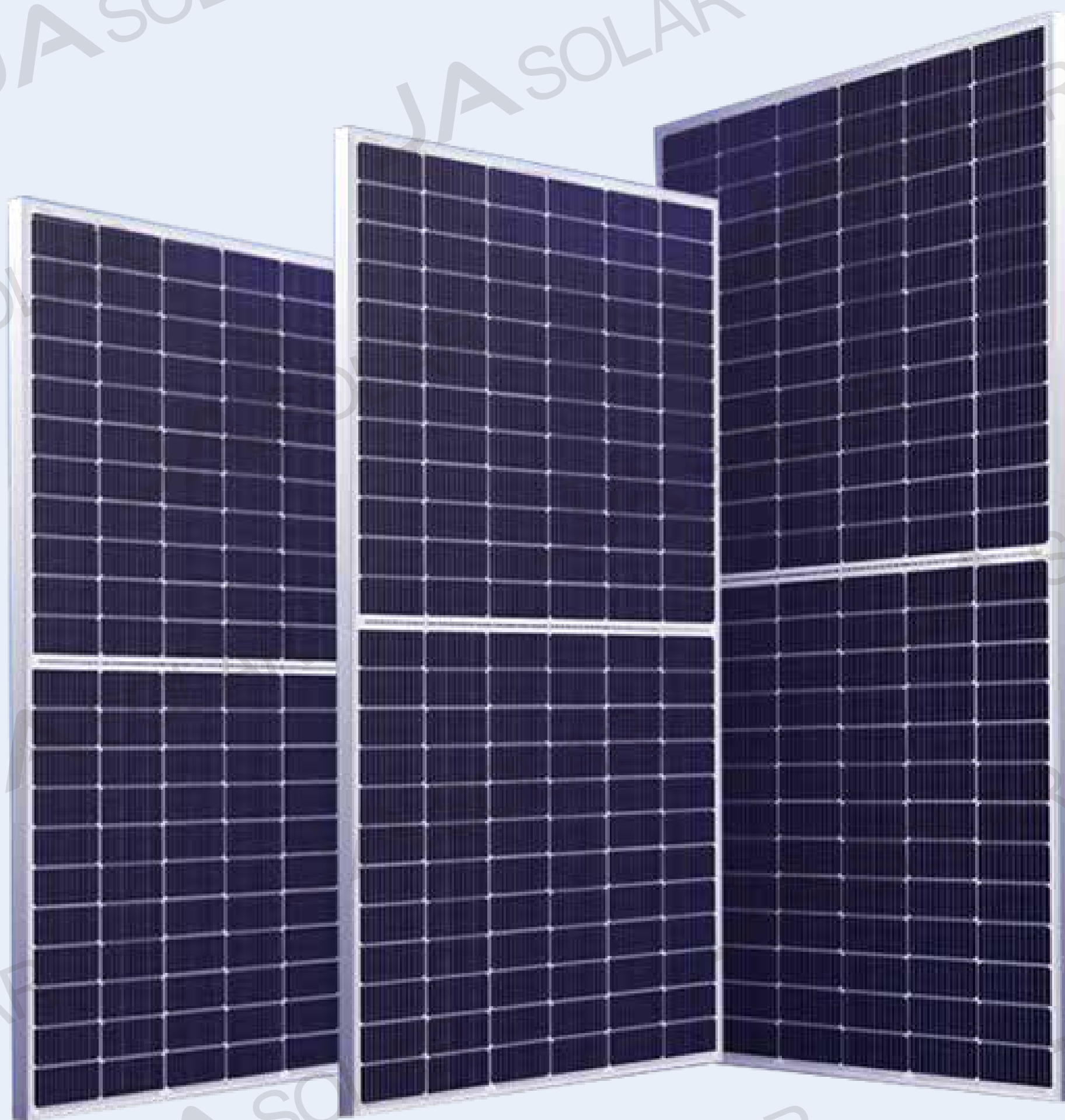

66-Cell

72-Cell

78-Cell

66/72/78-cell type of DeepBlue 3.0 modules

03 PART

CORE TECHNOLOGIES

In order to effectively reduce LCOE, DeepBlue 3.0 products have adopted multiple core technologies for reducing cost and increasing efficiency, including new-generation PERCIUM+ cells, gallium-doped silicon wafers, and multi-bus-bar, half-cell, and advanced module technologies, etc.

3.1 PERCIUM+ cells

Applying the new-generation high-efficiency PERCIUM+ cells, DeepBlue 3.0 series modules achieve more than 23.1% of average mass-produced cell efficiency by improving the passivation process on the front and back, superior low-irradiance power generation performance, and outstanding high-temperature power generation performance. The three-year outdoor testing data from 2017 to 2020 shows that the new-generation PERCIUM+ cells can generate power 2-3% more than those using the 1st generation technology.

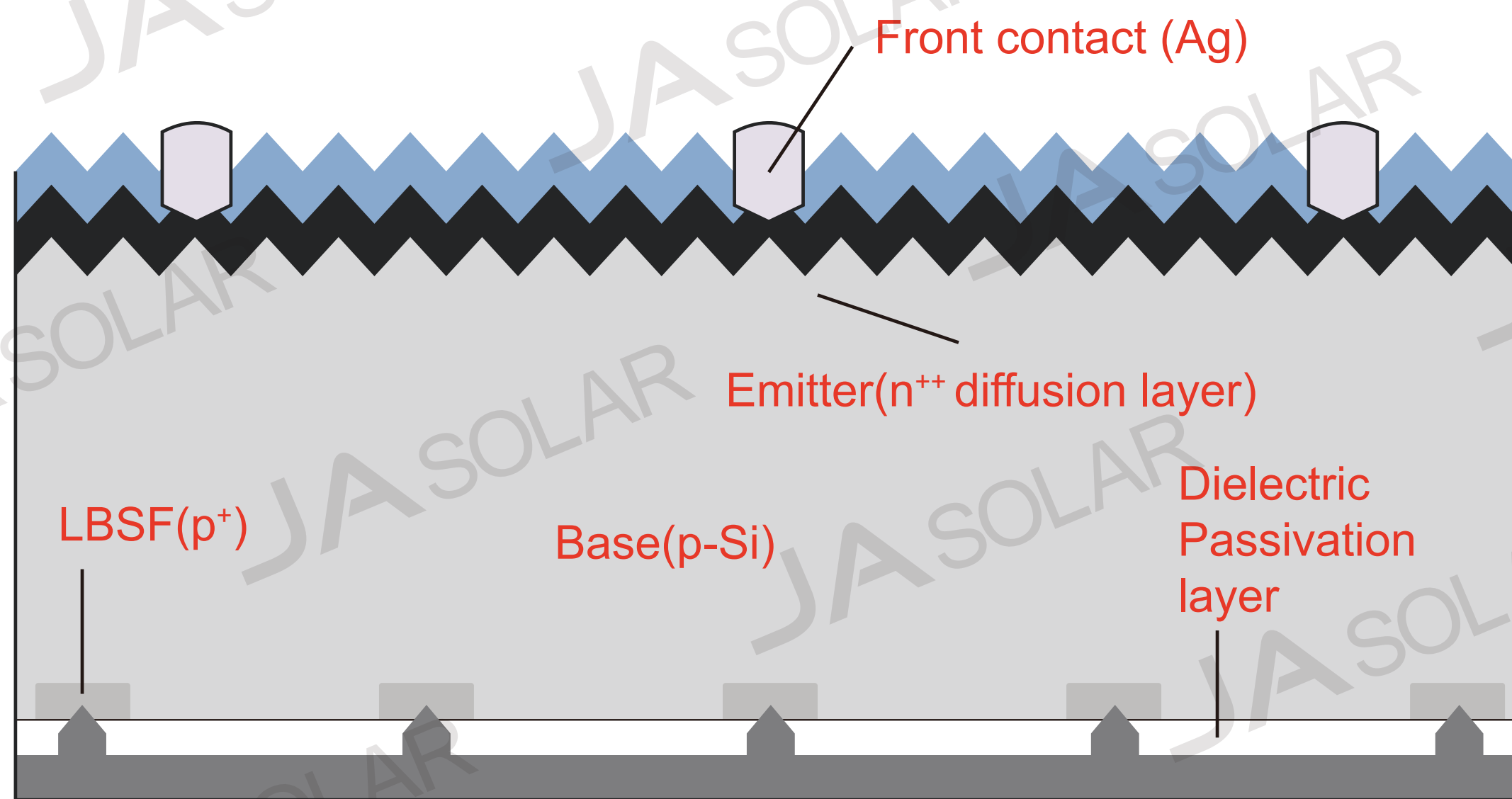

Back contact (Al)

1st generation

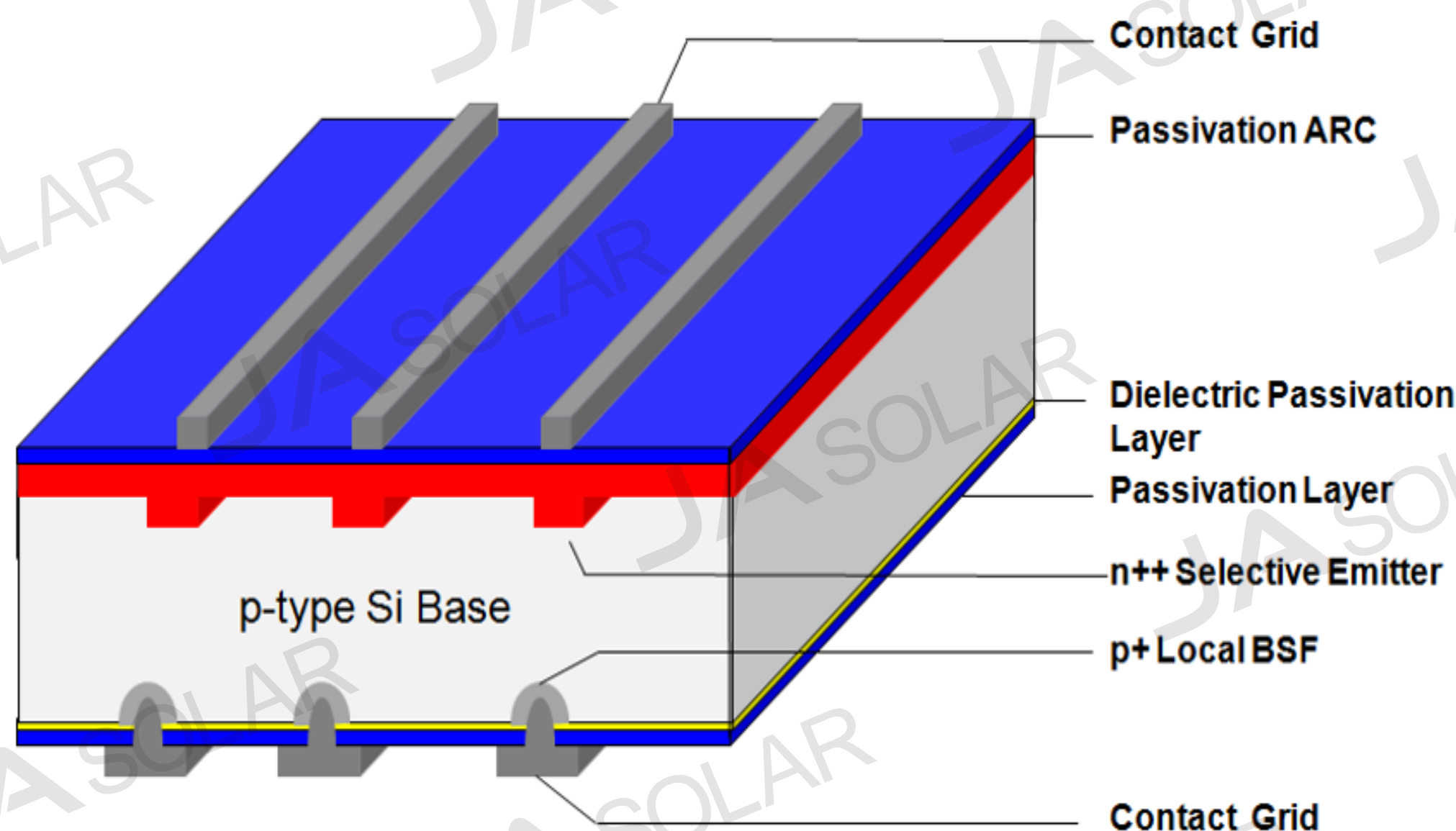

New-generation PERCIUM+

Structure diagram of two generations of PERCIUM cells

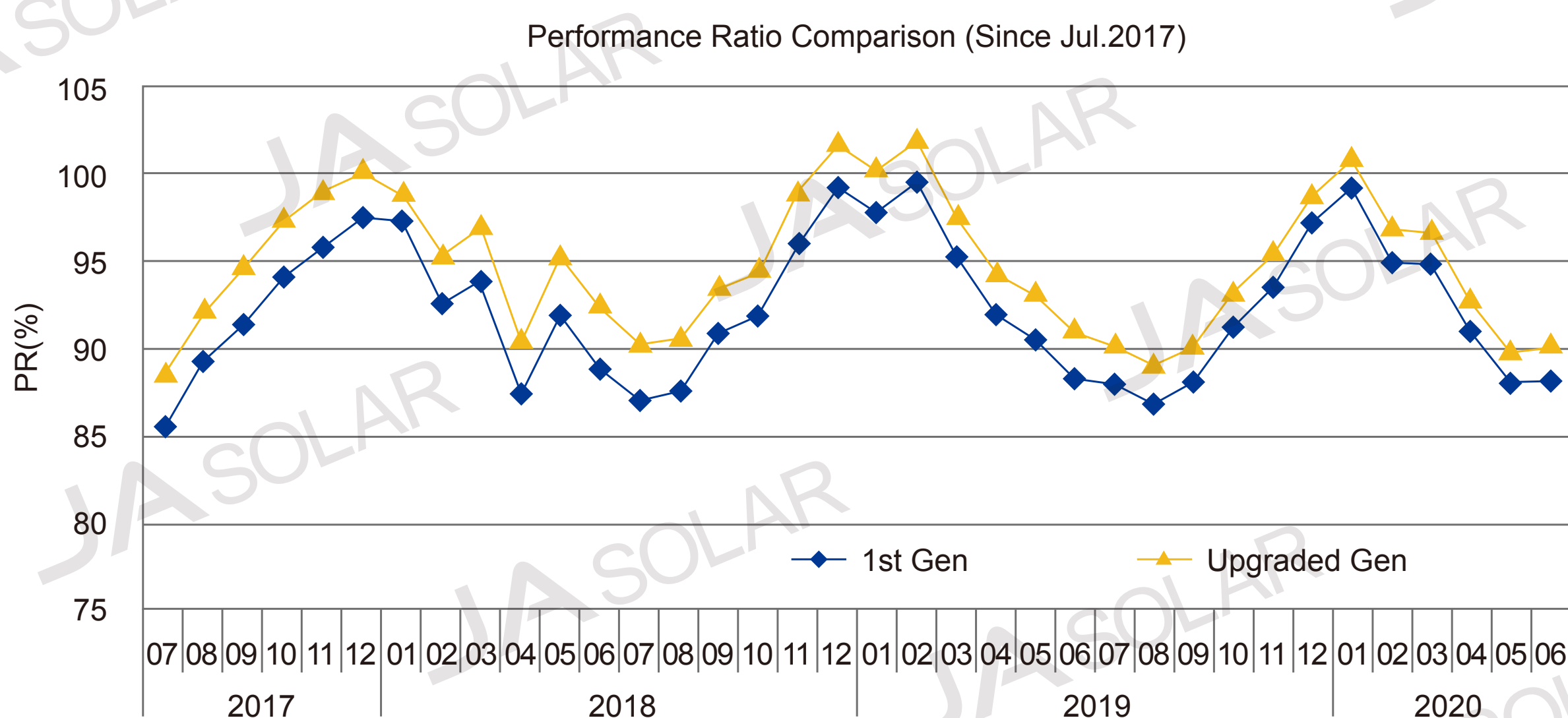

Comparison of outdoor tested power generation between two generations of PERCIUM cells

3.2 Gallium-doped technology

All high-efficiency mono-crystalline cells are made of gallium-doped silicon wafers, which have better anti-degradation performance and ensure durable and stable high-efficiency power generation. The first year degradation is within 2%.

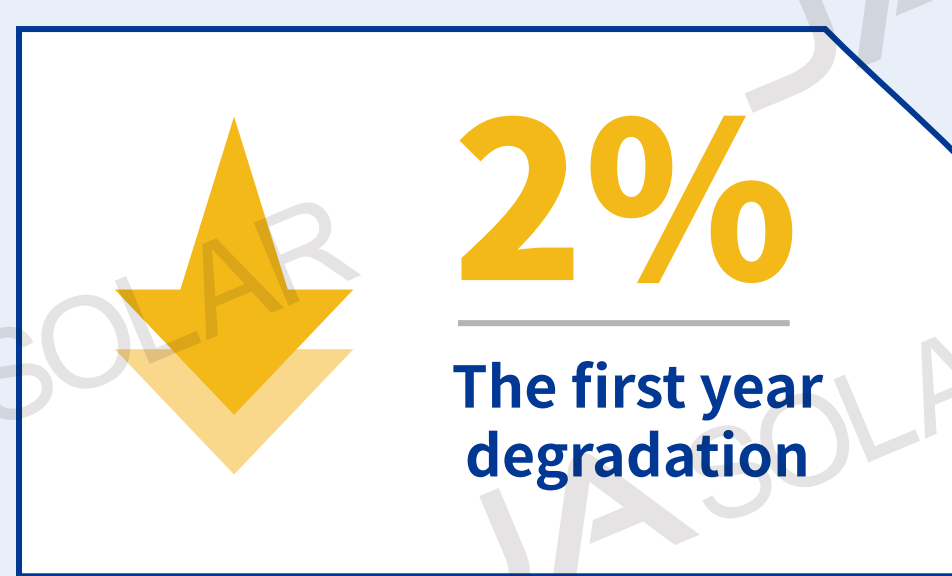

3.3 Multi-busbar cell technology

With MBB cell technology, DeepBlue 3.0 series modules identify 11 busbar as the best solution by taking comprehensive account of cell efficiency, production yield and cost, which have shortened the current transmission distance and reduced resistance loss, thus increasing the conversion efficiency of cells, and reducing the impact of broken grids and micro-cracks on module performance.

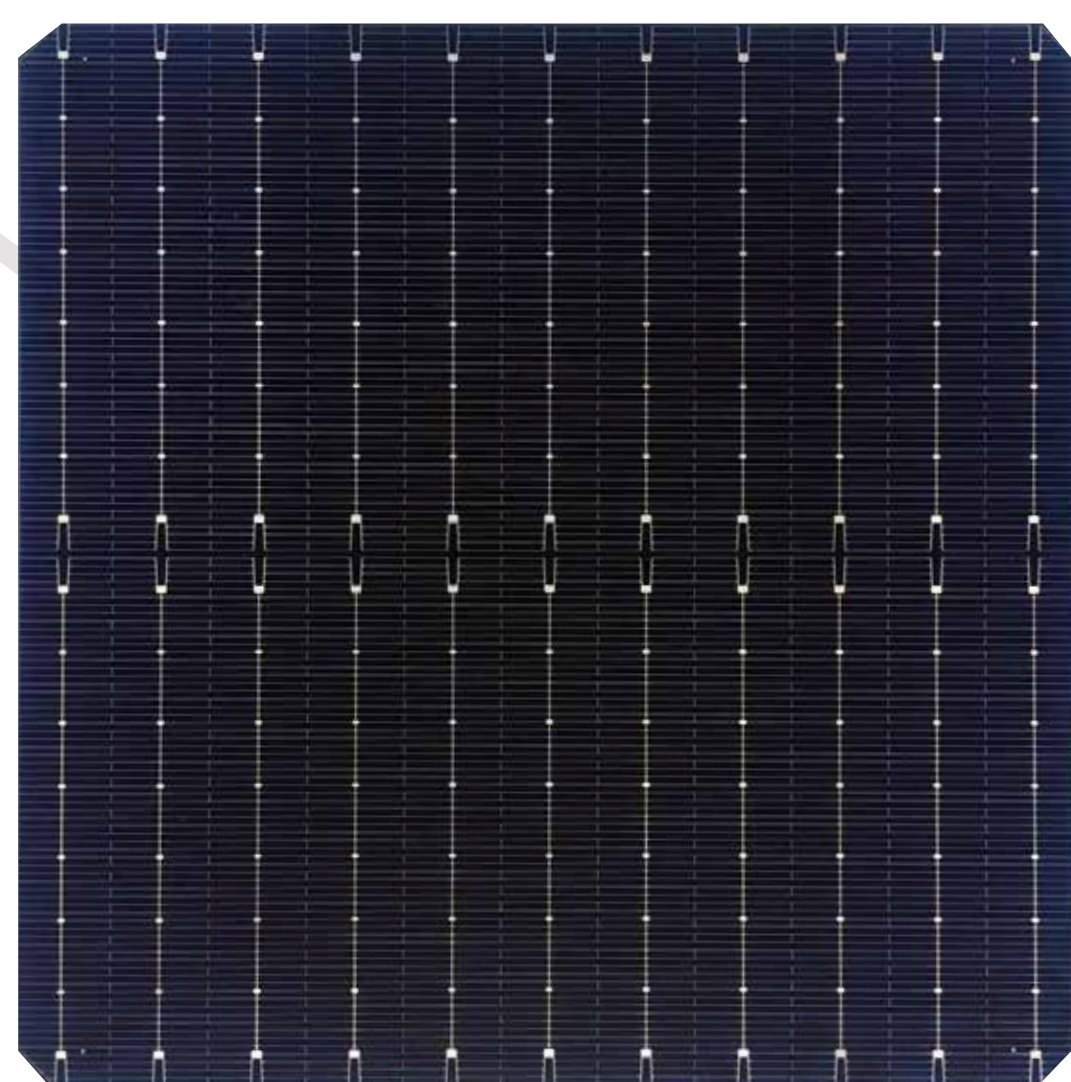

Cell with multi-busbar cell technology

The cells are designed with circular ribbons, and the IAM performance is better than those with conventional flat ribbons at the time of oblique light incidence. Moreover, more busbar designed with smaller diameter circular ribbons can reduce the impact of stress, and effectively improve the high and low temperature resistance performance and mechanical load performance of modules.

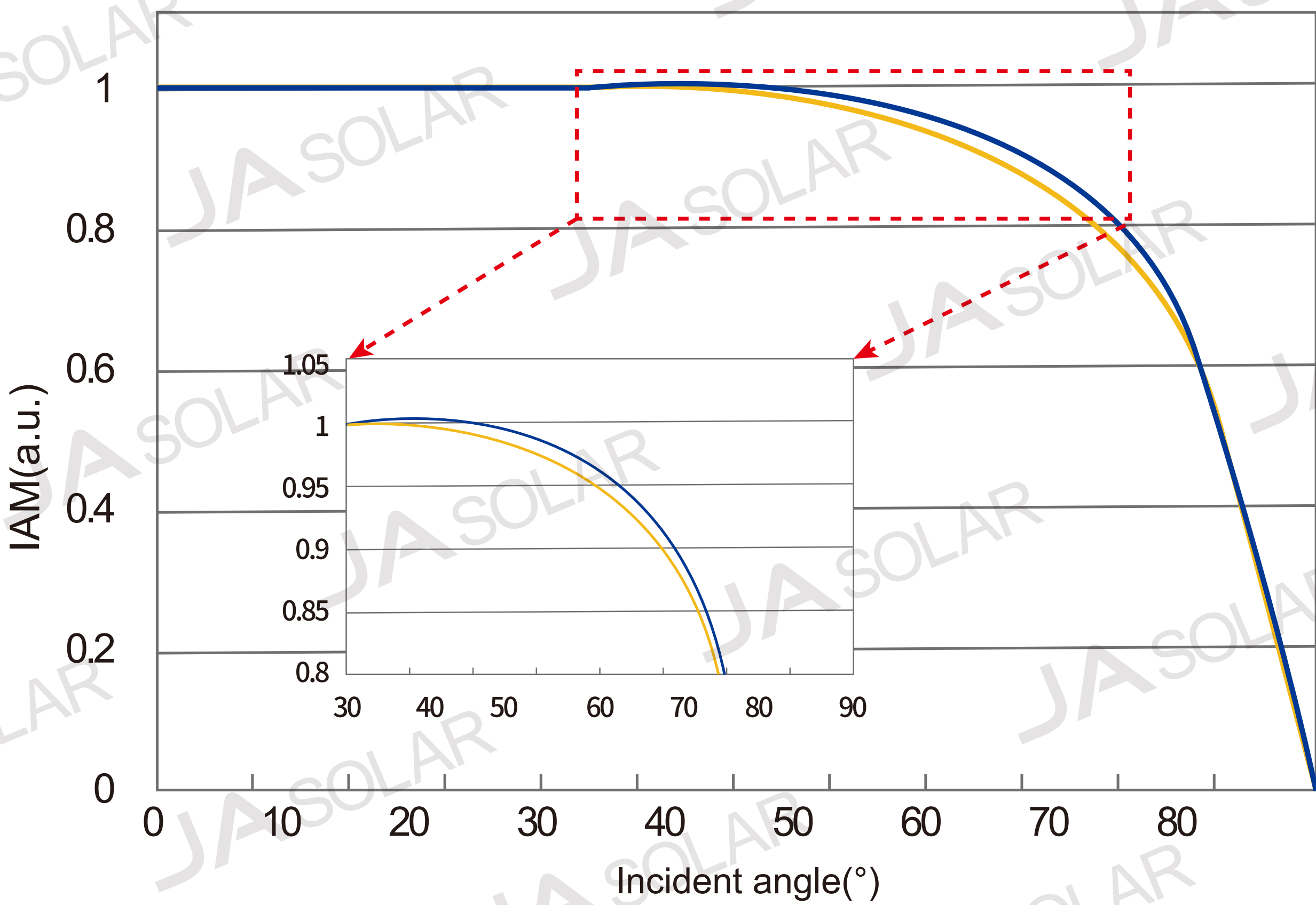
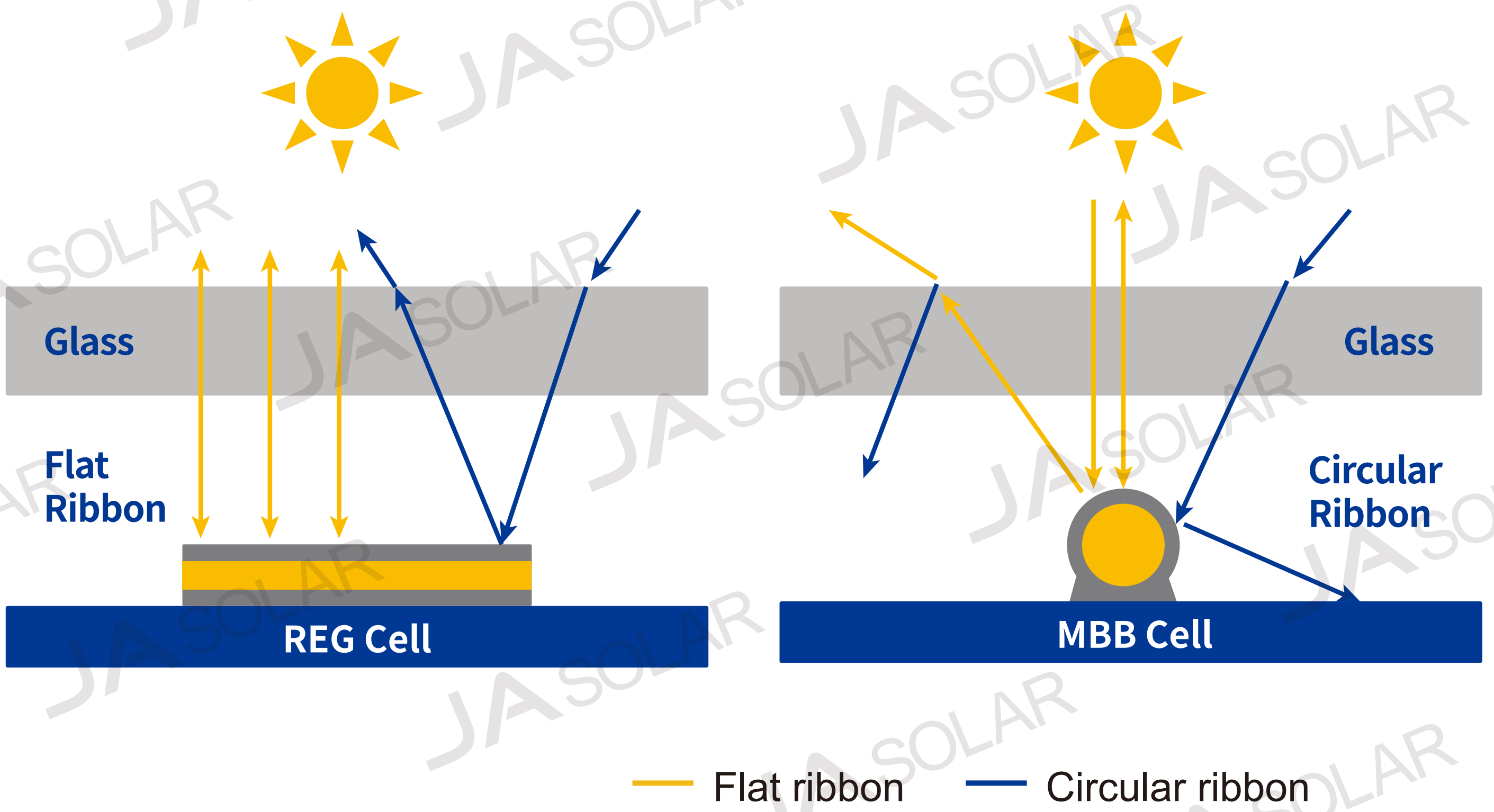

Circular ribbon design and IAM performance advantages

3.4 Half-cell technology

Adopting the half-cell technology, DeepBlue 3.0 series modules have both higher conversion efficiency and lower normal operating cell temperature (NOCT). The working temperature of half-cell modules is 2-3°C lower than that of full-cell modules, and the hot spot temperature of half-cell modules is 10-20°C lower than that of full-cell modules. In addition, half-cell modules have lower shading loss.

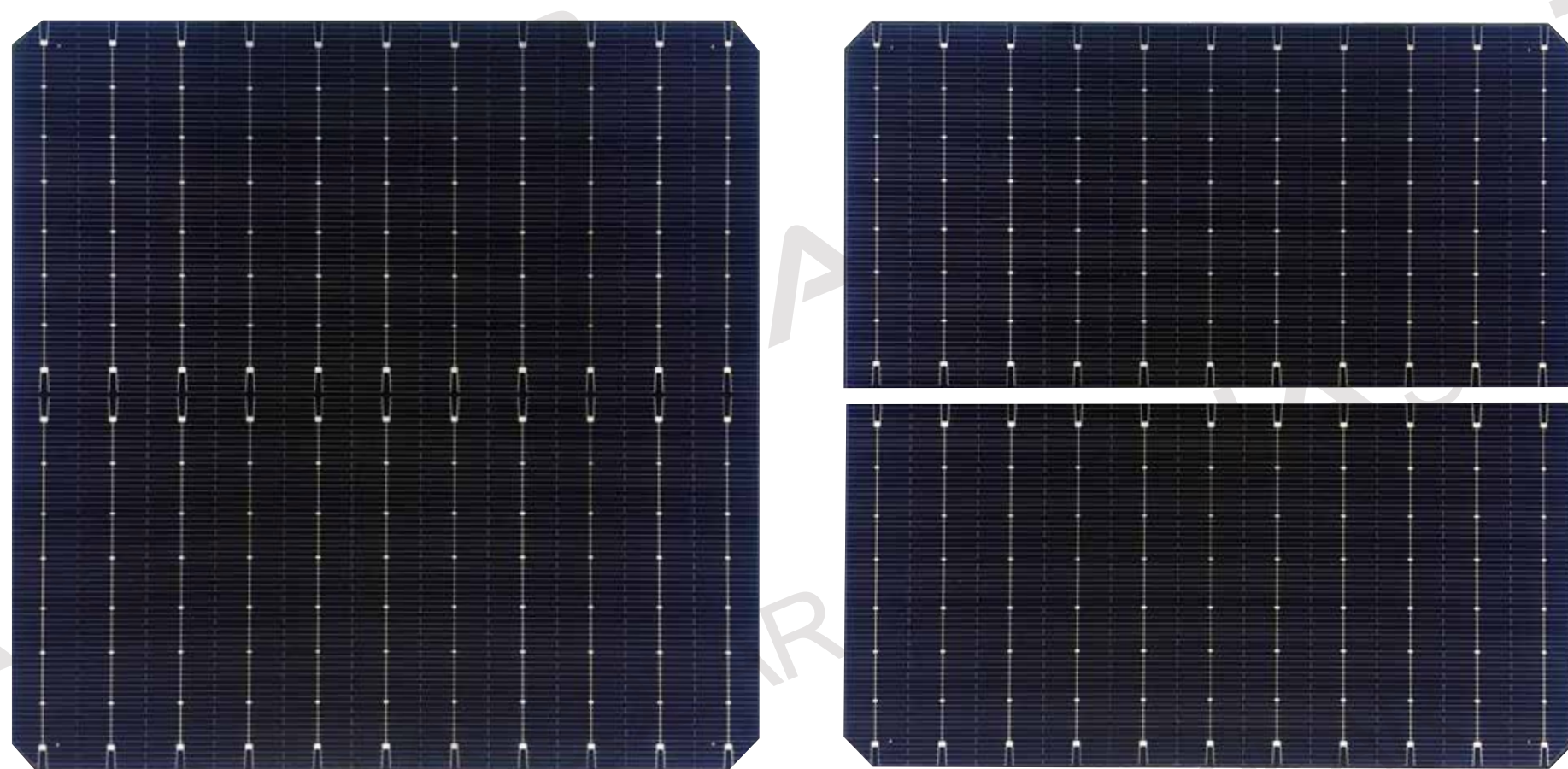

Full cell and half cell

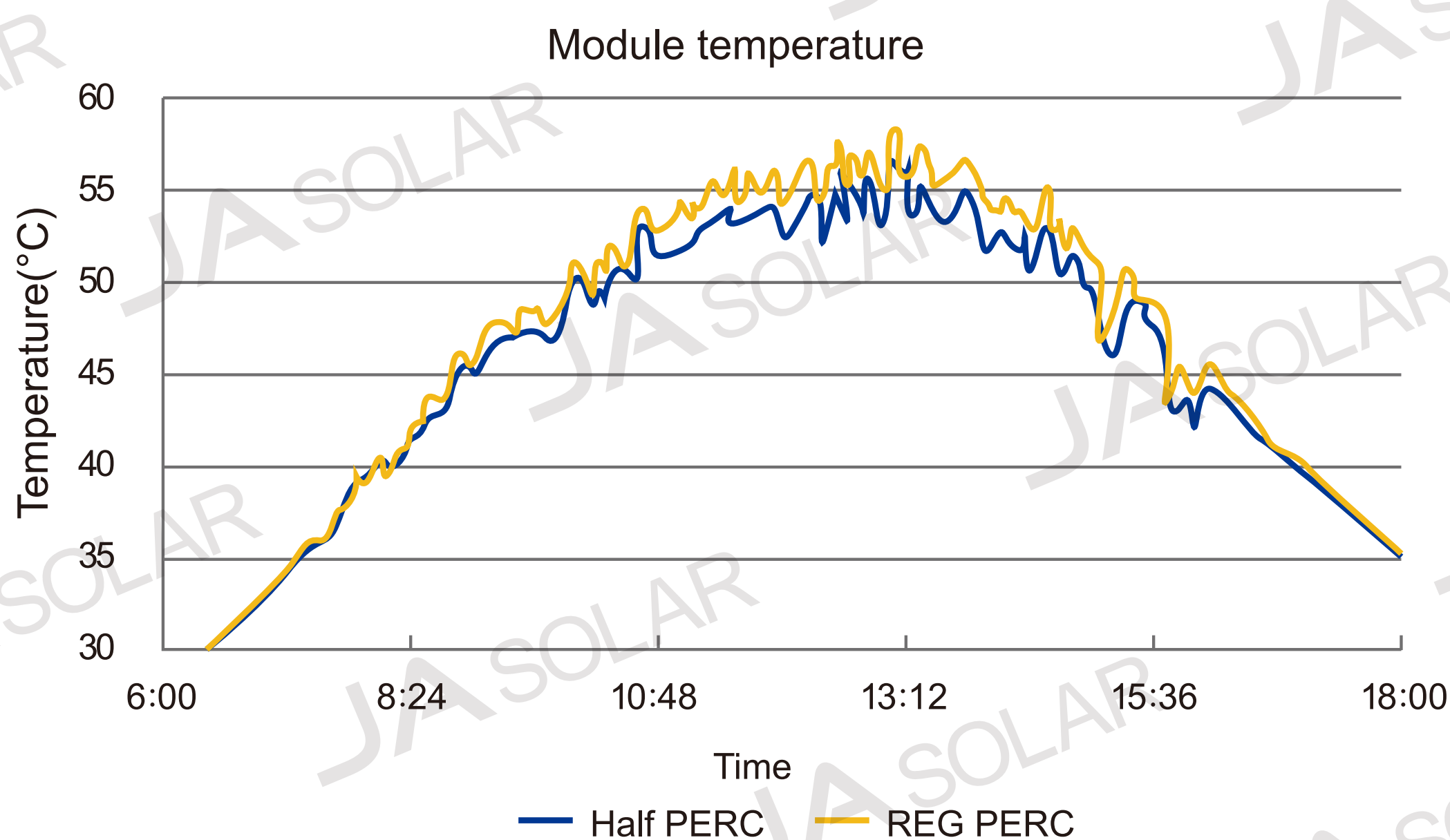

Working temperature of full-cell and half-cell modules

3.5 Advanced module technologies

DeepBlue 3.0 series modules gain higher conversion efficiency and reliability with the following improvements in module process and materials:

- ◆ high-transmittance glasses are used to improve light transmittance and weather resistance of the modules.
- ◆ Encapsulation film and backsheet are optimized to improve the power and reliability of the modules.
- ◆ cell-cutting technology is improved to reduce the damage from laser and improve the product reliability.
- ◆ with optional innovative slot frame design, the modules feature lighter weight, more convenient installation and better performance in mechanical load.

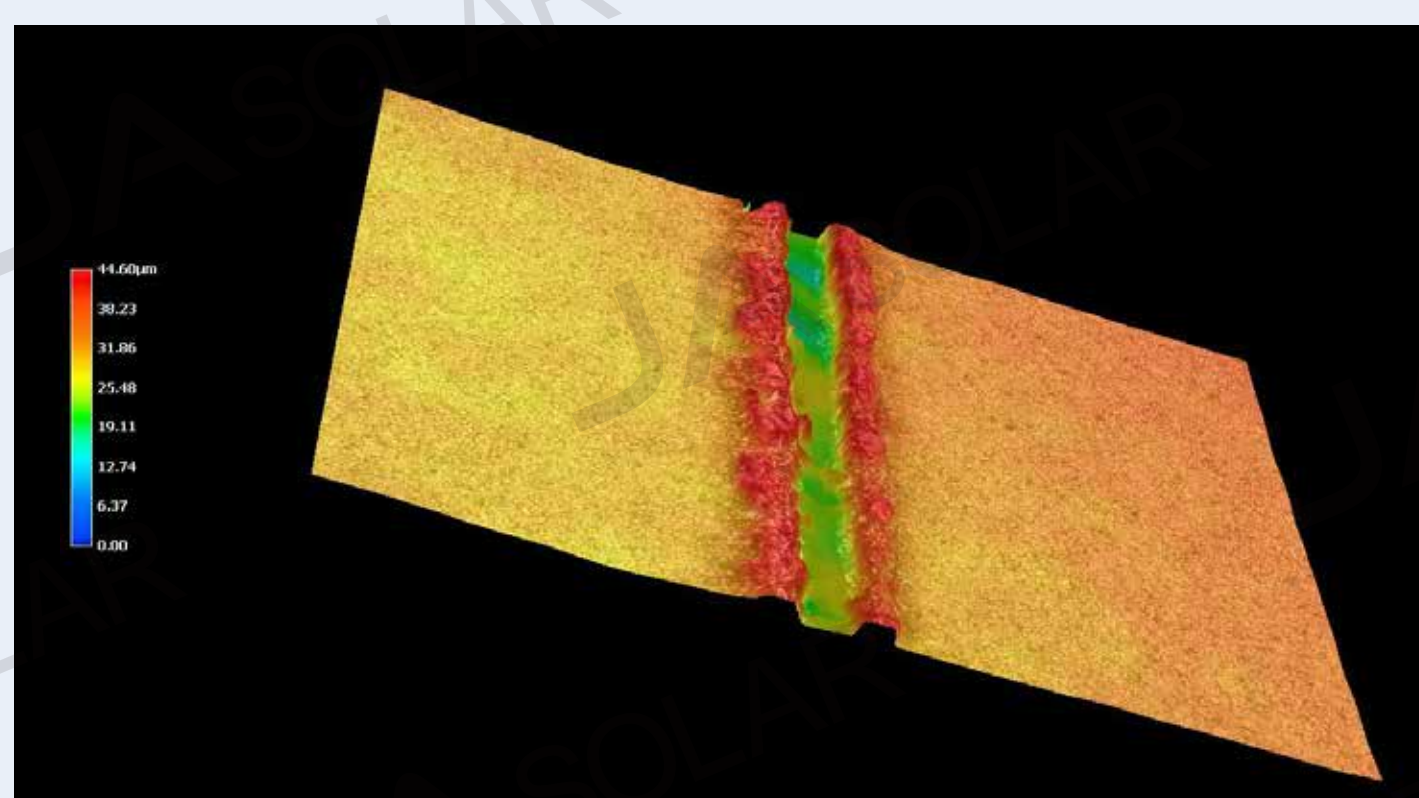

Improvement in laser-cutting technology

Advanced module technologies(1)

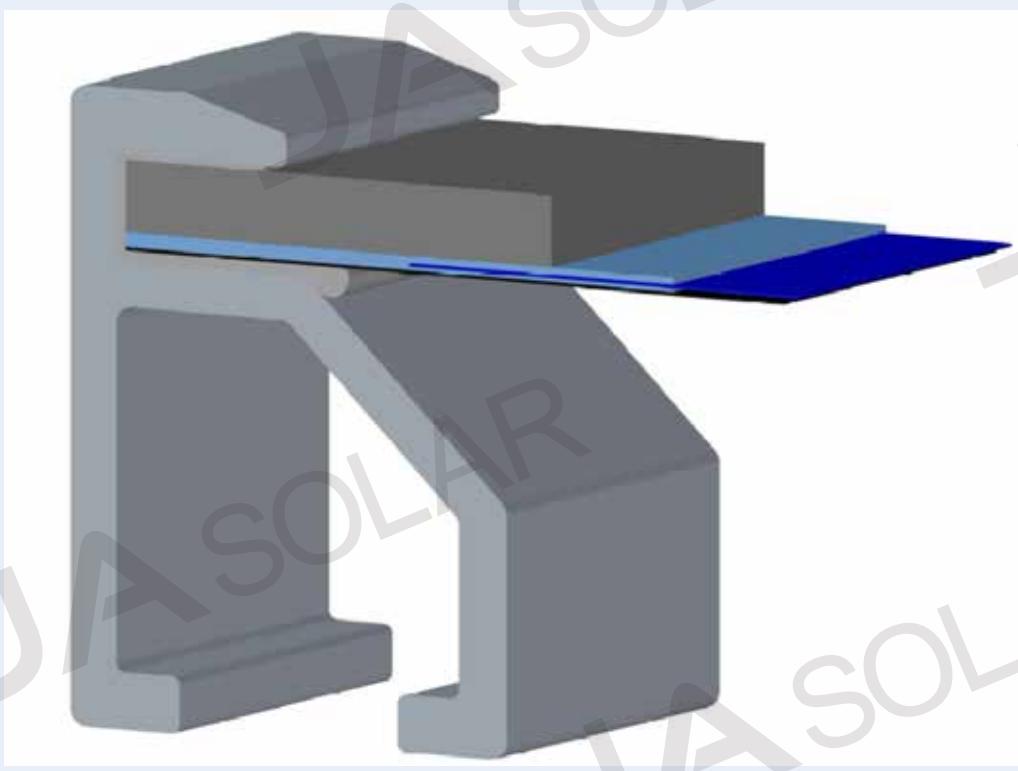

Innovative slot frame design
Advanced module technologies(2)

04 PART

PRODUCT HIGHLIGHTS

4.1 Customer value

While LCOE is a core indicator for evaluating PV power generation projects, it manifests the value of JA Solar to provide customers with solutions with minimum LCOE.

DeepBlue 3.0 modules can significantly reduce BOS costs of the system, especially the cost for structure (accounting for approximately 10% of the system costs). Compared with other types of modules, DeepBlue 3.0 modules have the optimal price advantages regardless of whether they are installed with fixed structure or trackers.

Schemes	210-5X10	210-6X10	182-6X12	182-6X13	166-6X12
Inverter	0.0000	0.0000	0.0000	0.0000	0.0000
Inverter installation	0.0002	0.0002	0.0002	0.0002	0.0002
Packaged substation	0.0068	0.0068	0.0068	0.0066	0.0068
Construction and installation of packaged substation	0.0006	0.0006	0.0006	0.0006	0.0006
Communication	0.0002	0.0002	0.0002	0.0002	0.0002
Cable	0.0077	0.0068	0.0074	0.0074	0.0102
Cable wiring	0.0025	0.0023	0.0025	0.0025	0.0035
Supports and pile foundations	0.0342	0.0306	0.0298	0.0288	0.0357
Subtotal (USD/W)	0.0521	0.0474	0.0474	0.0462	0.0571

Source: Third-party EPC company

Module model	210-5X10	210-6X10	182-6X12	182-6X13	166-6X12
Module size(mm)	2187*1102*30	2172*1303*40	2285*1134*35	2471*1134*35	2117*1052*35
Mainstream Power(W)	495	590	540	590	455
Open-circuit voltage (Voc)	51.5	41.3	49.6	53.3	49.75
Short-circuit current (Isc)	12.21	18.31	13.86	13.93	11.46
Maximum Power Point Voltage (Vmp)	42.6	34.2	41.64	44.8	41.52
Maximum Power Point Current (Imp)	11.63	17.25	12.97	13.17	10.96
Module efficiency (Eff)	20.7	20.8	20.8	21.1	20.4
Tacker Saving(%)	4%	8%	8%	14%	baseline

Source: Frontline tracker manufacturers

In addition, taking Dubai 360MW project as an example, compared with ordinary 410W modules, DeepBlue 3.0 modules (540W+) used in Dubai 360MW project reduced LCOE by 7%-9%.

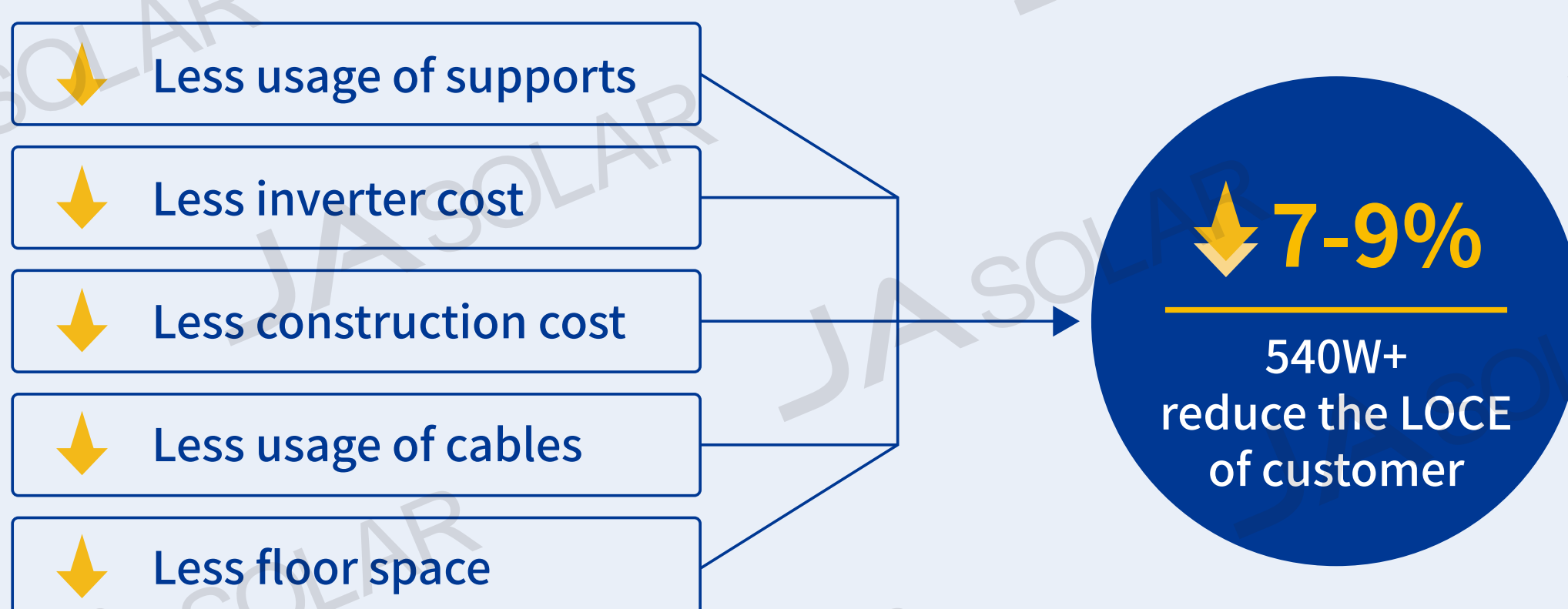

4.2 Guarantee for production capacity

Judging from the development trend of global PV industry, especially the potential of application market, and the product strategies of JA Solar, it is expected that by the end of 2021, the production capacity of DeepBlue 3.0 series modules will reach about 30GW, and JA Solar will be able to continue to provide customers with quality, high efficient and low-cost PV products and solutions with minimum LCOE in the future.

4.3 Guarantee for reliability

1) 30-year linear module peak power warranty

The power degradation in the first year is within 2%; linear power degradation for single-glass modules in 2-25 years is within 0.55%/year, and linear power degradation for dual-glass modules in 2-30 years is within 0.45%/year.

Power ratio (%)

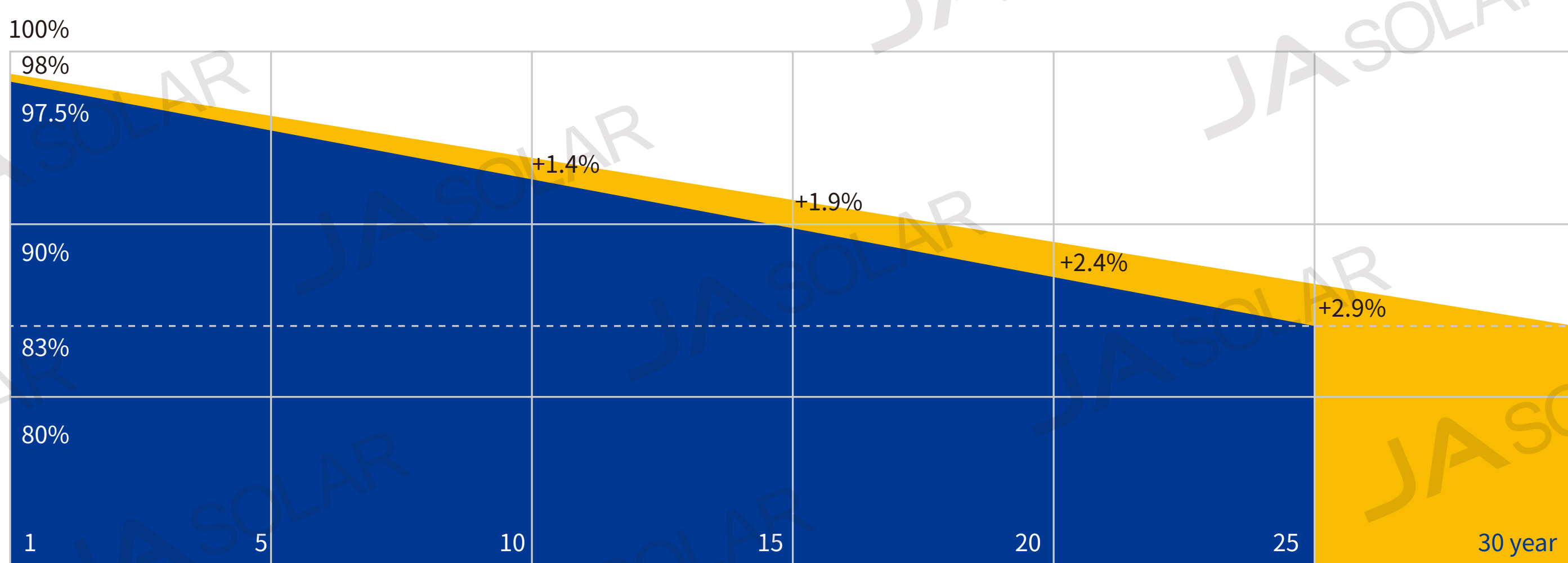

Superior Warranty (single-glass modules: blue, double-glass modules: yellow)

2) Guarantee against hot spot risk

Based on 182mm x 182mm large-size silicon wafers, DeepBlue 3.0 modules feature high current as compared with modules with G1 and M6 silicon wafers (under the same serial and parallel structure of cells), leading to a relatively higher risk of hot spot. Nevertheless, the risk of hot spot of DeepBlue 3.0 modules is effectively controlled by the following methods.

- Cell leakage current control:** The magnitude of leakage current is directly correlated to the hot spot characteristics of PV modules. The less the leakage current is, the lower the hot spot temperature and hot spot risk will be. As shown in the diagram below, the percentage of cells with reverse leakage current controlled at 0-0.5A is more than 99%.

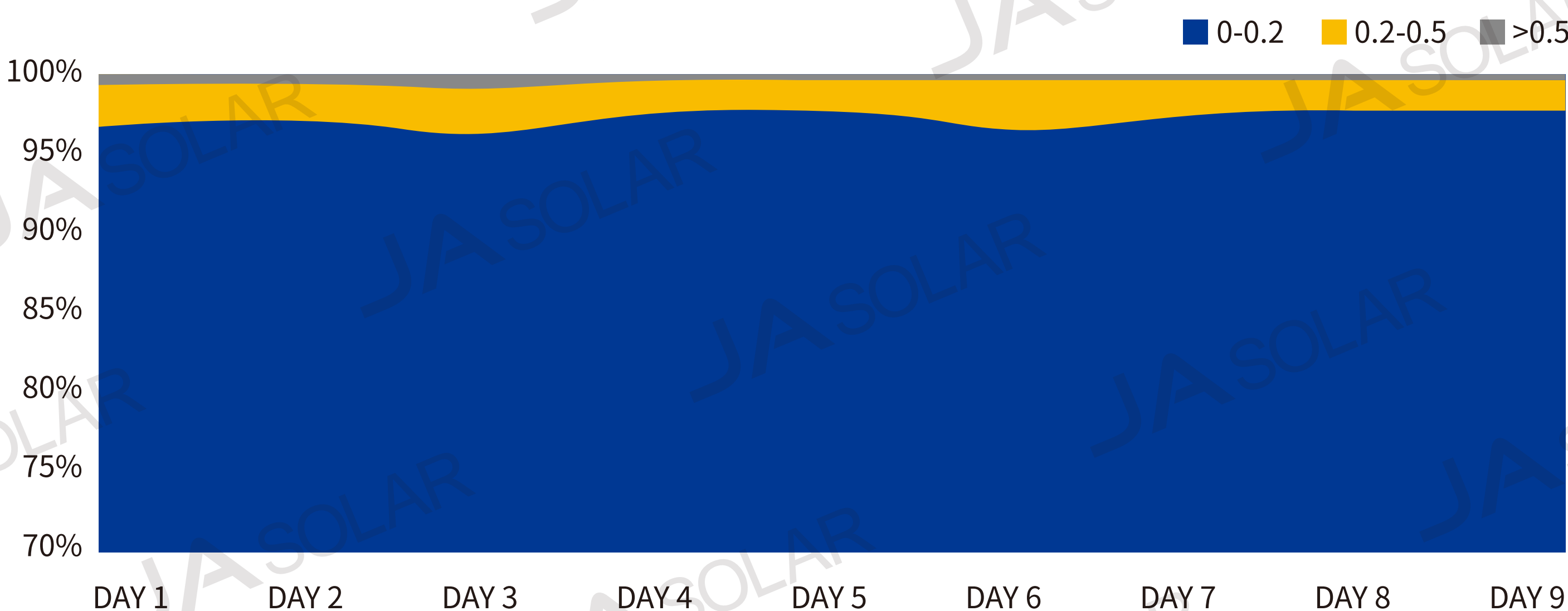

182 cells diagram of current leakage distribution trend

- ◆ **Non-destructive cutting:** Compared with traditional laser melting cutting, non-destructive cutting is adopted for DeepBlue 3.0 products; specifically, the cell is heated with continuous laser, followed by spray cooling, which creates a temperature gradient and hence thermal stress to crack the cell. This cutting method can not only significantly reduce the micro-cracks on the cut and improve the parallel resistance of the cell, but also effectively reduce the leakage current; moreover, the cutting surface is very smooth and the mechanical strength of the cut cell is close to that of an uncut one.
- ◆ **Optimization of auxiliary materials:** Encapsulation materials with better temperature resistance performance are used to improve the hot spot resistance of modules.

3) Mechanical load

The innovative slot frame design of DeepBlue 3.0 modules not only makes it easier for module installation, but also greatly increases the mechanical load performance of the modules. In addition, DeepBlue 3.0 modules are also compatible with the conventional clamp installation. The front static mechanical load of the modules can reach 5,400Pa and the back static mechanical load can reach 2,400Pa.

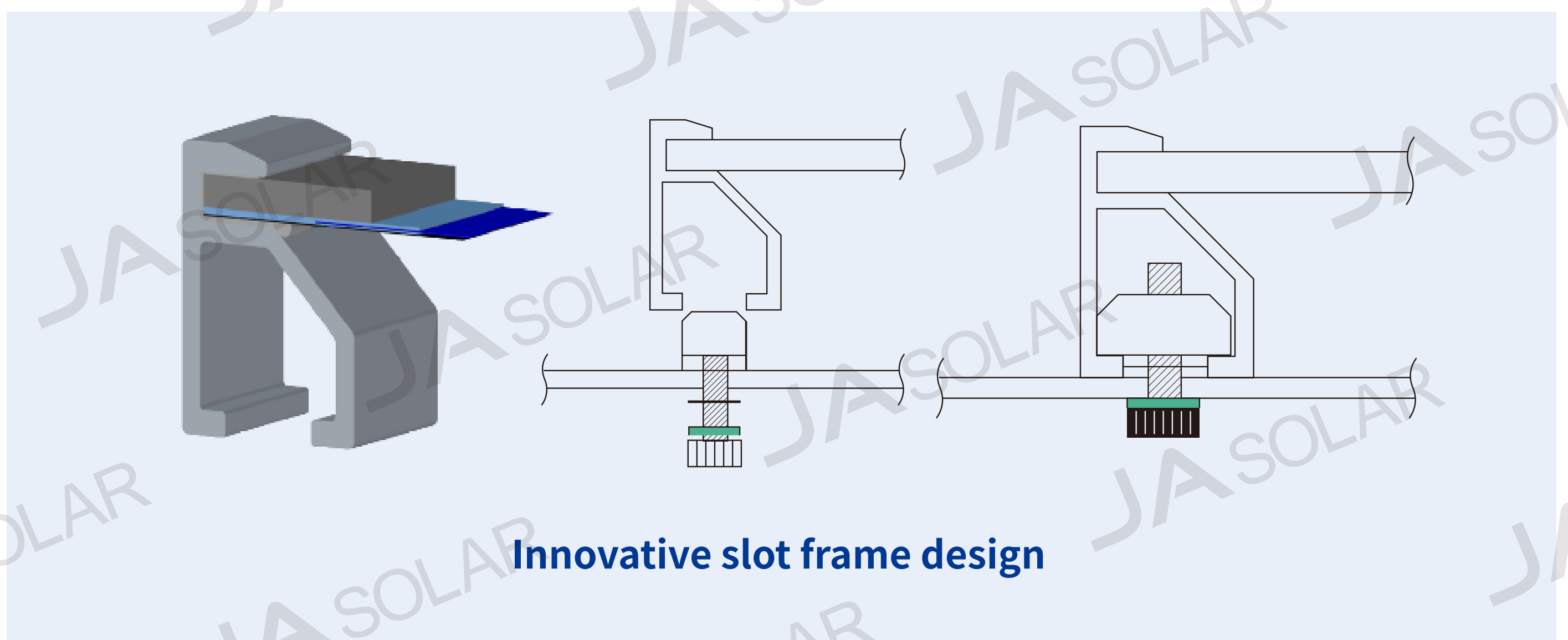

4.4 Comprehensive product and system certifications



IEC61215 IEC61730
UL61215 UL61730



ISO 9001:2015
Quality Management
Systems



ISO 14001:2015
Environmental
Management
Systems

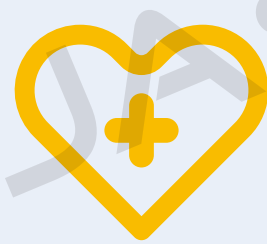

ISO 45001:2018
Occupational Health and
Safety Management Systems

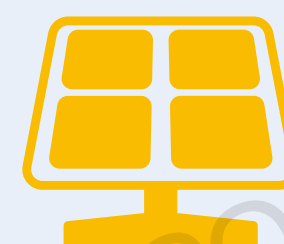

IEC TS 62941:2016 Terrestrial
photovoltaic(PV) modules
Guidelines for increased
confidence in PV module design
qualification and type approval

4.5 Low-cost logistics and transportation

DeepBlue 3.0 products are transported in containers. Compared with 158/166-size silicon wafers, the load wattage of products with 182mm x 182mm silicon wafers is 10-20% higher per container, which reduces transportation costs. From perspectives of transportation safety, cost and convenience, the current mainstream vertical packaging is adopted for DeepBlue 3.0 modules, which allows up to one layer of stacking with a space margin of 100mm. This kind of packaging makes for the loading and unloading of containers, maximizes the use of carrier space, and reduces the cost of transportation, highlighting the core of size design for DeepBlue 3.0 modules.



Packaging and transportation of DeepBlue 3.0 products

Type of Modules	Total Number of Modules (pcs)	Total Power (KW)
158	748	307
166	620	285
182	620	335

Container loading capacity

4.6 System compatibility

In the early stage of design of DeepBlue 3.0 modules, JA Solar Technology has comprehensively evaluated the compatibility of the modules with inverters. DeepBlue 3.0 modules are perfectly compatible with central inverters and string inverters. DeepBlue 3.0 modules are designed based on 182mm silicon wafers and can work at a current of around 13A, which is higher than the current for PV modules based on M2 and G1 size wafers. For central inverters, the inverter fuses, switches and other components can be upgraded to achieve perfect compatibility with 182mm modules; for string inverters, perfect compatibility can be achieved with 182mm modules when the power generation gain of bifacial modules reaches 15%, even without considering

the DC loss at the module side. According to the development trend of inverter technology, the power of both string inverters and centralized inverters will be gradually increased within a certain range, and the rated current will also be adjusted with the working current of modules.

In addition, DeepBlue 3.0 modules are perfectly compatible with the mainstream installations such as fixed structures and trackers. For installation of fixed structures, the support steel structure can be slightly adjusted in line with the changes in module size and weight, and it is easy to extend the length or width of fixed support structure. For installation of trackers, the tracker manufacturer needs to make recalculation according to the size and weight of modules to provide the most cost-effective solution.

05 PART

PERFORMANCE AND PARAMETERS

DeepBlue 3.0 modules is designed with an efficiency of up to 21% and excellent temperature coefficients, with detailed parameters set out in the table below.

electrical parameters at STC	JAM72S30 -545/MR	JAM78S30 -590/GR	JAM72D30 -540/MB	JAM78D30 -585/GB
Maximum power (Pmax) [W]	545	590	540	585
Maximum power voltage (Vmp) [V]	41.8	44.8	41.64	44.56
Maximum power current (Imp) [A]	13.04	13.17	12.97	13.13
Open circuit voltage (Voc) [V]	49.75	53.3	49.6	53.2
Short-circuit current (Isc) [A]	13.93	13.93	13.86	13.88
Module efficiency	21.09	21.10	20.84	20.90
Power tolerance	0~+5W			
Temperature coefficient of short circuit current (α -Isc)	+0.045%/°C			
Temperature coefficient of open circuit voltage (β -Voc)	-0.275%/°C			
Temperature coefficient of maximum power (γ -Pmp)	-0.350%/°C			
Warranty	2% in the first year, 0.55% annual degradation over 25 years		2% in the first year, 0.45% annual degradation over 25 years	
Weight (Kg)	28.6	31.1	31.6	33.4

Main technical parameters of DeepBlue 3.0 series modules

Guided by the core value of “customer first”, JA Solar Technology has always focused on technological innovation, and is committed to providing efficient and reliable PV products for global customers. It has won common recognition from the PV industry and global customers. As steady as it has been, JA Solar Technology, based on market demand, has launched the currently most stable and mass-producible DeepBlue 3.0 products to provide global customers with the best choice of modules that can effectively reduce LCOE and increase revenue of power plants. The major breakthrough in the power of DeepBlue 3.0 modules is an important step in JA Solar Technology’s ongoing process of improving product performance and long-term benefits for users. In the future, JA Solar Technology will continue to focus on product technology innovation, promote the development of the PV industry, and provide customers with higher quality and more reliable products, so as to let more people benefit from the development of clean energy.

Harvest the Sunshine

JA Solar Technology Co.,Ltd.

Add: Building No.8, Nuode Center, East Auto Museum
Road, Fengtai District, Beijing 100160, China

Tel: +86 10 6361 1888 Fax: +86 10 6361 1999

E-mail: sales@jasolar.com marketing@jasolar.com

JA-20210312